

---

# DEDICA MAESTRO PLUS EC950

COFFEE MACHINE  
Instruction for use



For more details please check out the  
De'Longhi How to videos



---

**DeLonghi**

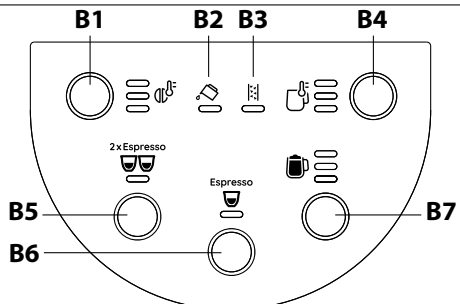
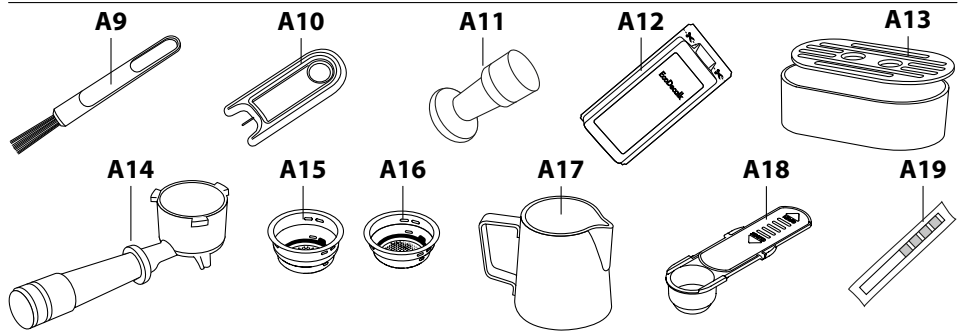
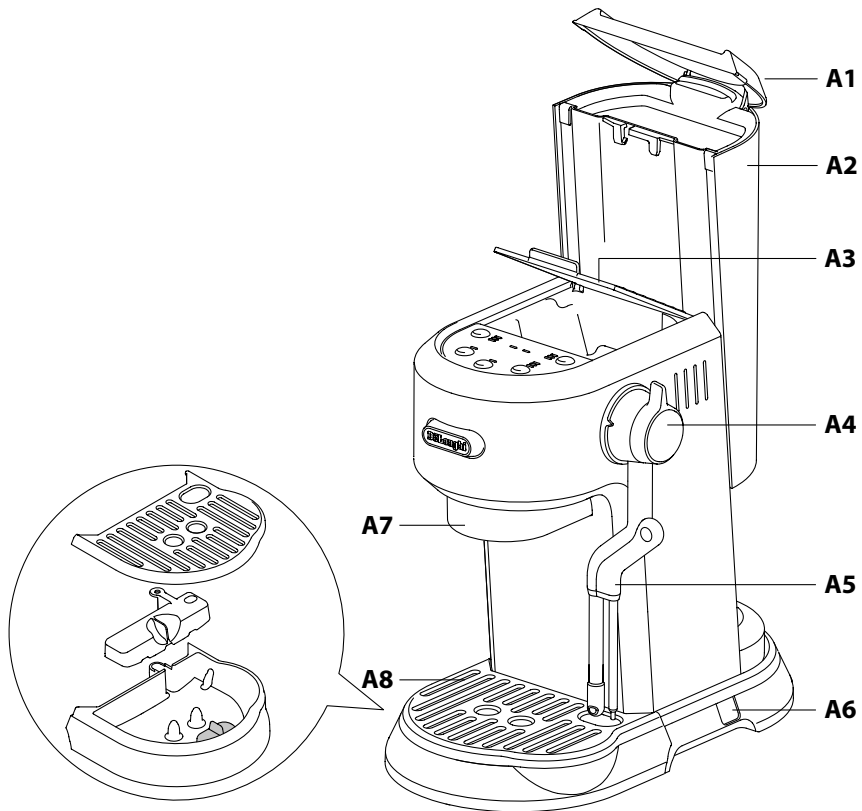

Before using the appliance, always read the safety warnings.

## 1. DESCRIPTION OF APPLIANCE

- A1. Water tank lid
- A2. Water tank
- A3. Accessory door
- A4. Steam lever
- A5. Steam wand
- A6. On/Off switch
- A7. Coffee spout
- A8. Drip tray
- A9. Brush
- A10. Cleaning needle
- A11. Tamper
- A12. Descaler (some models only)
- A13. Small cup tray
- A14. Filter holder
- A15. 2 cups filter
- A16. 1 cup filter
- A17. Milk jug
- A18. Measuring spoon
- A19. Water hardness test indicator paper

### 1.1 Control panel

- B1. Infusion temperature button
- B2. Water tank indicator light
- B3. Descale indicator light
- B4. Milk temperature button
- B5. 2 x Espresso button
- B6. Espresso button
- B7. Froth level button

## 2. FIRST USE

- Wash and dry all accessories, including water tank (A2) with warm water and soap. The drip tray, milk jug and small cup tray, are dishwasher safe.

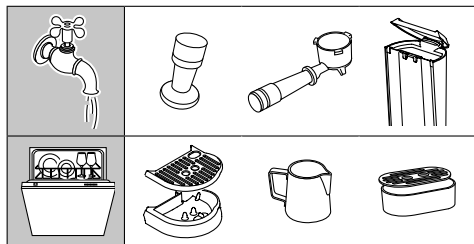

- Extract the water tank by pulling it upwards (fig 1).

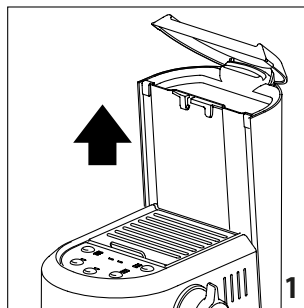

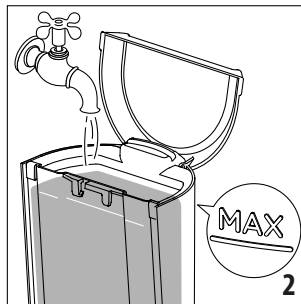

- Open the water tank lid (A1) and fill the water tank (A2) with fresh clean water, taking care not to exceed the MAX level (fig 2).

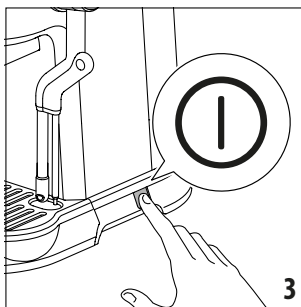

- Put the water tank back in the machine, pressing lightly to open the valves located on the bottom of the tank.
- Connect the appliance to a mains socket. Turn the machine on by pressing the On/Off switch (A6) (fig. 3).



- The water tank indicator light (B2) blinks and  (B6) button is on.
- Press the  (B6) button (fig. 4). Delivery begins and stops automatically. Empty the drip tray.



Before using the coffee maker, the internal circuits of the machine must be rinsed. Proceed as follows:

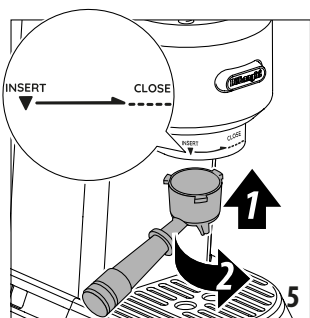

- Place the cups filter (A15) or (A16) in the filter holder (A14).
- Attach the filter holder to the machine aligning the filter holder handle with "INSERT", then turning the handle to the right until it is aligned in the "CLOSE" position (fig. 5).



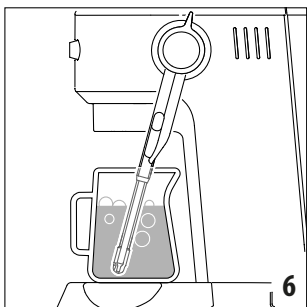

- Place a container under the filter holder.
- Press the Espresso (B6) button. The appliance delivers water from the filter holder. Repeat this operation 5 times.
- Put a jug with cold water under the steam wand (A5) and do an 'autosteamer' (fig. 6) (see the Autosteamer paragraph).



**Please note:** Never operate the machine without water in the water tank or without the tank.

The appliance has a water levels sensor. If while brewing the selected beverage, the  (B2) indicator light blinks, the water in the water tank is running out. It is possible to complete the delivery of the selected beverage. The  (B2) indicator turns on when the water tank is empty. Fill the water tank with fresh water. It is normal for there to be water in the space under the tank. This should therefore be dried regularly with a clean sponge.

### 3. MAKING ESPRESSO COFFEE

- Turn the machine on by pressing the On/Off switch (A6) (fig. 3). If the machine is in stand-by mode, press any button on the control panel.
- The  and  indicator lights blink to indicate the machine is heating up (fig. 7).

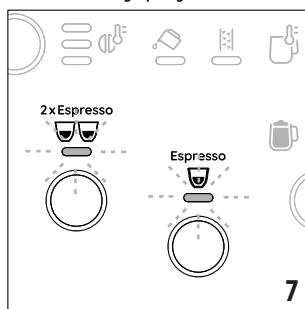

When the lights stop blinking and all the indicator lights on the control panel remain steadily, the machine is ready for use.

- Place the cup filter (A15) or (A16) in the filter holder (A14) (fig. 8).

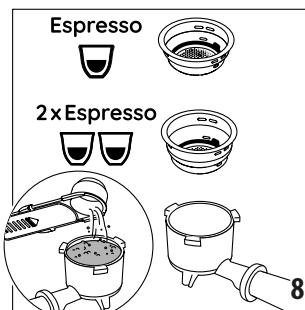

- Fill the cup filter with ground coffee using the measuring spoon (A18). Make sure that you are using a fine grind, specific for espresso. Before filling the coffee filter with ground coffee, make sure there are no coffee residues left in the filter from the last time you made coffee.

- Tap the filter holder several times to distribute the coffee evenly in the cup filter.
- Press down firmly with the tamper (A11). Make sure the coffee is at the recommended dose level after tamping (fig. 9).

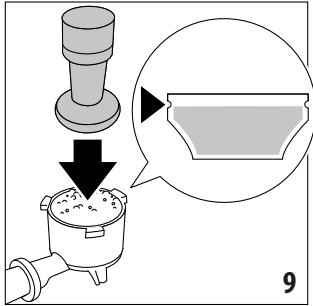

You may need to add some coffee. Tamping correctly the ground coffee is essential to obtain a good espresso. If you press too firmly, the coffee will be delivered slowly and will be strong. If you press too lightly, the coffee will be delivered quickly and will be weak.

**Barista Tips:** Before placing the filter holder into the machine, run a short flow of water through the coffee spout (A7). This will stabilise the temperature before the extraction.







- Remove any excess coffee from the rim of the filter holder and attach the filter holder to the machine (fig. 5).
- Place one cup or two cups on the drip tray (A8) under the filter holder spouts. Use small cup tray (A13) for smaller cups.



### 3.1 Coffee preparation temperature

The water temperature is controlled during the entire preparation process to ensure its stability during the extraction step. The machine has 3 infusion temperatures.

The temperature effectively utilized will depend typically on the variety of beans and the roast: Robusta beans require a lower temperature, and Arabica beans a higher temperature. The same applies for dark roasted beans or for light roasted beans, respectively.

- Press  (B1) button to set the desired level of infusion temperature:

Temperature level	Corresponding indicator light	Roast level
Min (~ 92°C)	 	Dark
Med (~ 94°C) (default)	 	Medium-dark
Max (~ 96°C)	 	Light - medium





- Press  (B6) or  (B5) button. The machine proceeds to make the coffee and delivery is interrupted automatically. While the machine is making coffee, delivery can be interrupted at any moment by pressing the button pressed previously.
- To remove the filter holder, turn the handle from right to left. To avoid splashes, never remove the filter holder while the machine is delivering coffee. Always wait for a few seconds after delivery.



**Please note:** You are recommended to warm the cups before making coffee:

Rinsing them with a little hot water or attach the filter holder (A14) to the machine with the cup filter (A15 or A16) in place but without adding coffee, using the same cup as will later be used to make the coffee, press the  (B6) button and deliver hot water into the cup to heat it.

### 3.2 Programming the quantities of coffee in the cup

The machine is set by default to automatically deliver standard quantities. To change these quantities, proceed as follows:





- Press the  or  button and hold for a least 3 seconds, until the indicator light relative to the selected drink starts to blink, indicating that the machine is in programming mode.
- The coffee maker starts delivering coffee.
- When the desired quantity has been reached, press the  or  button again: the quantity is programmed.

	Default quantity	Programmable quantity
Espresso 	35ml	from ≈20 to ≈90 ml
2x Espresso 	70ml	from ≈40 to ≈180 ml

To return to the quantities of default see instructions in section 5.4.

## 4. MAKING MILK BEVERAGES

### 4.1 Automatic steaming

- Fill a milk jug (A17) with fresh cold milk (between the MIN and MAX position!). Milk will up to triple in volume. For a denser more even froth, you must use milk at refrigerator temperature (about 5°C).
- Press  (B4) button to set the desired milk temperature:
  -   Min temperature (60°C)
  -   Med temperature (65°C) (default)



High temperature (70°C)

- Press the  (B7) button to set the desired type of milk texture:



LatteArt - Microfoam texture





Fine texture



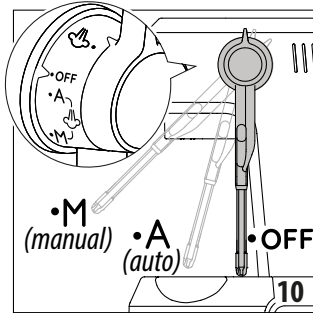

Dense texture (default)

- Lift the steam wand (A5) in “M” position (fig. 10) in order to facilitate the milk jug (A17) positioning under the steam wand.

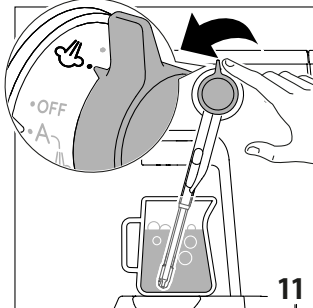

- Position the steam wand in “A” (autosteaming) position. Turn the steam lever (A4) in position  (fig. 11).



- The  indicator light blinks. The machine proceeds to make the froth and delivery is interrupted automatically. Remove with a soft damp cloth any milk residues from the steam wand. Put the steam wand to “OFF” position after each use to start the automatic rinsing.

#### 4.2 Manual steaming:

**Please note:** Milk froth and temperature setting are not selectable for this functionality.

- Fill a milk jug (A17) with fresh cold milk (between the min and max position!). Milk will up to triple in volume. For a denser more even froth, you must use milk at refrigerator temperature (about 5°C).

- To make the froth manually, place the steam wand in “M” (manual steaming) position, place the milk jug under the steam wand and turn the steam lever in position  (fig. 12).

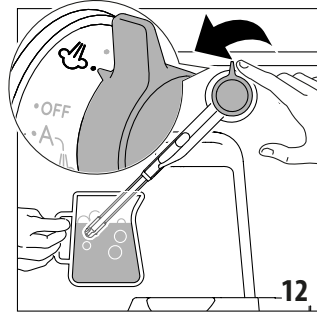

- To froth the milk, rest the steam wand on the surface of the liquid. This mixes air with the milk and steam. Keep the steam wand in contact with the surface, taking care not to let in too much air and create excessively large bubbles.

Immerse the steam wand below the surface of the milk, this creates a vortex in the liquid.

During Manual steaming milk temperature indicator light will inform you about the reached milk temperature (60-65-70°C)

- Once the milk is heated to the desired temperature, turn again the steam lever in  position.
- Wait until steam stops completely before removing the milk jug.

Put the steam wand to “OFF” position after each use to start the automatic rinsing.

**Barista tips:** Fresh milk is recommended. Always use fresh milk straight from the fridge.

For best results, always place the milk jug in the fridge when not in use.

Whole milk is recommended. The appearance and texture of froth depending on the nature of the dairy milk or vegetable beverages utilized.

After frothing the milk, eliminate unwanted bubbles by swirling the jug gently.

**Please note:** During normal operation of the machine, some water is discharged in the drip tray to ensure optimal performance.



After every use, remove with a soft damp cloth any milk residues from the steam wand and place it in “OFF” (auto clean) position. The appliance delivers water from the steam wand.



A rinse is performed automatically when the appliance switches off if the steam wand remains in “A” (autosteaming) position.

If the wand remains in “M” position after a steaming,  and

 indicator light will blink, to warn you about the necessity of putting the wand in OFF position to perform the automatic rinsing.

## 5. MENU SETTINGS

Press and hold the  (B1) and  (B4) buttons for 3 seconds to enter the menu settings. After few seconds of inactivity, the machine automatically exits the menu.

The  (B2) and  (B3) indicator lights blinks.

The following settings will be saved after few seconds, when appliance exit automatically by menu setting.

### 5.1 Delay time between pre-infusion and infusion

Increasing the delay changes the time the water comes into contact with the coffee, changing the flavor profile.





To set the delay time, press  (B1) button:

 No preinfusion delay

 1 second (default)

 2 seconds

### 5.2 Descale

To set descale function, press  (B6) button; the  (B3) indicator light blinks and the  indicator light turns on. Press and hold the  (B6) button for 3 seconds to start descaling (see instructions in section Descaling).

If you accidentally activate descaling, you can stop it by pressing and holding the  (B6) button for at least 10 seconds.

### 5.3 Auto-off

To set the Auto-off time press  (B7) button:



 5 minutes (default)

 1.5 hour

 3 hour

If the machine is in Auto-off mode, press any button on the control panel to turn on the appliance.



### 5.4 Default values

To reset the default values press  (B5) button; the indicator light blinks. Press and hold the  (B5) button for 3 seconds to resets all menu settings.

All settings will be restore to factory.

### 5.5 Water hardness

To set the one of the 3 levels of water hardness, press  (B4) button:

Water Hardness Test Result	Corresponding indicator light	Level
■		1 soft water
■ ■		2 medium water
■ ■ ■ ■ ■ ■ ■ ■ (default)		3 hard or very hard water

## 5.6 Measuring water hardness

The  (B3) indicator light comes on following a predetermined period of operation that depends on a water hardness setting. The machine can also be programmed according to the actual hardness of the local water supply, in which case descaling may be required less frequently.

- Remove the water hardness test indicator paper (A19)  from its pack.
- Immerse the paper completely in a glass of water for one second.
- Remove the paper from the water and shake lightly. After about a minute, 1, 2, 3, or 4 red squares form, depending on the hardness of the water.

## 6. CLEANING

**Important:** Before maintenance or cleaning of the appliance, turn it off, unplug from the main socket and allow to cool.

Do not use solvents, abrasive detergents or alcohol to clean the coffee machine. Do not use metal objects to remove encrustations or coffee deposits as they could scratch metal or plastic surfaces. The drip tray, milk jug and small cup tray, are dishwasher safe. If the machine is not used for more than one week, before using it again, we strongly recommend you perform a rinse cycle.

The following parts of the machine must be cleaned and dry regularly:

- drip tray (A8):** the drip tray should be emptied and cleaned after each use or when the level indicator (red) rises through the metal grid. Remove the drip tray, empty the water and clean the drip tray with a cloth, dry and then reassemble the drip tray until you hear a 'click'.
- cups filter (A15), (A16):** After using the appliance, always rinse the filters under abundant running water. Use the brush (A9) to clean. Extract the perforated filter by pulling the tab and rinse the filters under running water. Make sure the holes are not blocked. If necessary, clean with a needle (fig. 13). Wipe dry with a cloth. Reposition the perforated filter in its seat and push fully home.

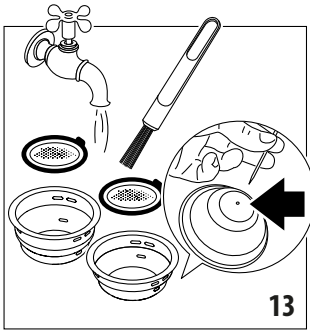

- **coffee spout (A7):** After every 200 coffees, rinse the coffee spout by delivering about 0.5 l of water from the coffee spout (press the Espresso (B6) button without using ground coffee).
- **water tank (A2):** Clean the water tank regularly (about once a week) and whenever you replace the water softener filter (if present) with a damp cloth and a little mild washing up liquid, especially internally in the sensor area (fig. 14); rinse with running water.

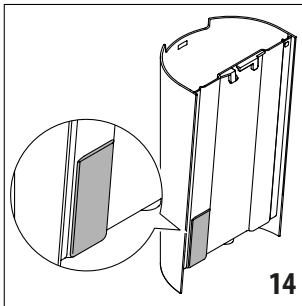

- **steam wand (A5):** After every use, remove with a soft damp cloth any milk residues from the steam wand. Lift the steam wand and place it in "OFF" (auto clean) position (fig. 10). The appliance delivers water from the steam wand. Wait that the steam wand cool down and open the hole of the nozzle with the cleaning needle (A10) (fig. 15).

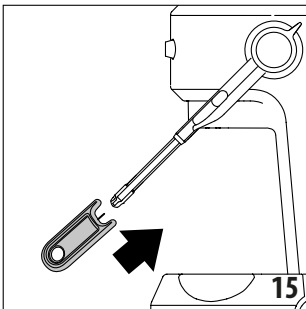

## 7. DESCALING ☹️

Before use, read the instructions and the labelling on the descaler pack.

It is important to use De'Longhi descaler only. Using unsuitable descaler and/or performing descaling incorrectly may result in faults not covered by the manufacturer's guarantee.

Descaler could damage delicate surfaces. If the product is accidentally spilt, dry immediately.

- Descale the machine when the ☹️ (B3) indicator lights turns on.
- Remove and empty the drip tray (A8), then reposition it in the machine.
- Empty the water tank (A2) (if present, remove the water softener filter).
- Pour the descaler into the water tank up to the level 'A' marked on the inside of the tank.
- Add water (1 litre) up to level 'B'. Now reposition the water tank in the machine.
- Make sure the filter holder (A14) is not attached and position a recipient under the hot coffee spout (A7) and steam wand (A5).
- Press and hold the ☹️ (B1) and ☹️ (B4) buttons for 3 seconds.
- Press Espresso (B6) button; the ☹️ (B3) indicator light blinks and the ☹️ (B6) indicator light turns orange.
- Press and hold the Espresso (B6) button for 3 seconds to start descaling. The indicator light (B6) starts blinking.
- The descale programme starts and the descaler liquid comes out of the steam wand and coffee spout. The descale programme removes limescale deposits from inside the appliance by automatically performing a series of rinses and pauses until the water tank is empty.
- Delivery stops and the ☹️ (B2) indicator light turns on, the ☹️ (B6) indicator light turns white.
- Empty and rinse the water tank.
- Fill the water tank to MAX level with fresh water and empty the recipient used to collect the descaler solution and replace it empty.
- Press the Espresso (B6) button to start the rinse cycle.
- When the rinsing process is over, the ☹️ (B3) indicator light goes out and descaling is complete and the appliance is ready to use.

**Please note:** If you accidentally activate descaling, you can stop it by pressing and holding the ☹️ (B6) button for at least 10 seconds.





## 8. TECHNICAL DATA

Voltage:	220-240V~ 50-60Hz
Absorbed power:	1450W
Max. water tank capacity:	1.6 l
Size LxDxH:	207x346x328 mm
Weight:	5 kg

## 9. STATISTICS

This mode allows you to have all the statistics data.

- Make sure the machine is turned off.
- Press and hold the  (B5) button for 3 seconds and simultaneously press the On/Off switch (A6) to enter the Statistics settings.
- Press the following buttons to select the appliance's data:

Buttons	Data
	total automatic frothing time (minutes)
	water quantity delivered (liters)
	total numbers of coffee beverages
	total numbers of descalings
	total numbers of steam delivered

### 9.1 Indicator light:

 number of blinks to indicate units (from 1 to 9)

 number of blinks to indicate tens (from 10 to 90)

 number of blinks to indicate hundreds (from 100 to 900)

 number of blinks to indicate thousands (from 1000 to 9000)

 number of blinks to indicate tens of thousands (from 10000 to 90000)

## 10. TROUBLESHOOTING

<b>Problem</b>	<b>Cause</b>	<b>Solution</b>
There is water in the drip tray (A8)	This water comes from the internal circuits of the machine and is a normal consequence of their operation	Empty and clean the drip tray on a regular basis
No espresso coffee is delivered	No water in the water tank (A2)	Fill the water tank
	Coffee ground too finely	Adjust the quantity and grinding level
	Blockage in the cups filter (A15) or (A16)	Rinse the filters under running water
	The water tank (A2) is not properly in place and the valves at the bottom are not open	Press down lightly on the tank to open the valves at the bottom
The espresso coffee drips from the edges of the filter holder (A14) rather than the holes	Limescale in the water circuit	Descale the appliance
	The filter holder has been inserted incorrectly or is dirty	Attach the filter holder correctly and rotate firmly as far as it will go
The espresso coffee drips from the edges of the filter holder (A14) rather than the holes	Blockage in the cup filter (A15) or (A16)	Rinse the filters under running water
	The coffee spout gasket has lost elasticity or is dirty	Clean the coffee spout gasket. Have the coffee spout gasket replaced by Customer Services
The filter holder (A14) cannot be attached to the machine	Too much coffee has been placed in the filter	Use the measuring scoop (A18) supplied and make sure you are using the correct filter for the type of preparation
The coffee crema is too light (delivered from the spout too fast)	The pre-ground coffee is not pressed down firmly enough	Tamp the pre-ground coffee more firmly
	There is not enough pre-ground coffee	Increase the quantity of pre-ground coffee
	The pre-ground coffee is too coarse	Use only pre-ground coffee for espresso coffee makers
	The wrong type of pre-ground coffee is being used	Change the type of pre-ground coffee
The coffee froth is too dark (delivered from the spout too slowly)	The pre-ground coffee is pressed down too firmly	Press the coffee down less firmly
	There is not enough pre-ground coffee	Reduce the quantity of pre-ground coffee
	The espresso coffee spout (A7) is blocked	Clean the coffee spout
	The cup filter (A15) (A16) is blocked	Clean the cup filter
	The pre-ground coffee is too fine	Use only pre-ground coffee for espresso coffee makers
	The pre-ground coffee is too fine or damp	Use pre-ground coffee for espresso coffee makers only and make sure it is not too damp
After delivering coffee, the filter remains attached to the coffee spout		Insert the filter holder (A14) again, deliver coffee, then remove the filter holder
The water tank indicator (B2) blinking and Espresso led is on (B6)	Air in the hydraulic circuit	Verify water tank position and water presence. Press Espresso button (B6) and wait until delivery in the drip tray stops
The machine will not make any drink and the water tank light is on	No water in the water tank (A2) or no water tank in the machine	Fill the tank with water or insert the water tank
The machine does not function and all the lights flash		Disconnect the machine immediately and contact authorised Customer Services.
No milk froth is formed when making cappuccino	Milk not cold enough	Always use milk at refrigerator temperature
	If you are in "manual steaming", steaming procedure could be wrong	Review the "manual steaming" paragraph
	Nozzle is dirty	Clean the steam wand (A5)
No steam is produced	Limescale in the water circuit	Descale as described in section "Descaling"
	Nozzle is blocked/dirty	Clean the nozzle' hoses with the tool
Water sensor in the water tank is not working properly	Water tank is dirty	Clean the water tank internally, and dry the back panel
Descaling led is on	Descaling is required	Perform descaling

**Register Now**

[www.delonghi.com/register](http://www.delonghi.com/register)

